

L212 LOUDSPEAKER SYSTEM TECHNICAL INFORMATION

**For Use By Qualified Service
Technicians Only**

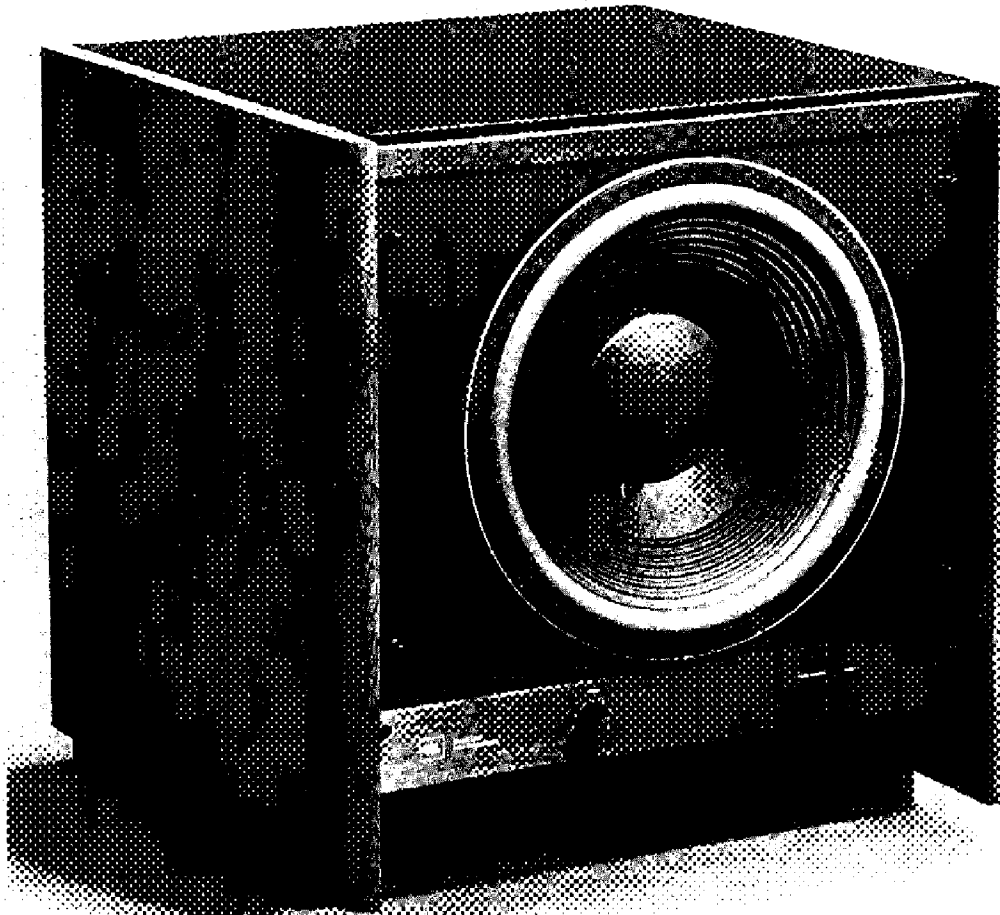

Bass Energizer Installed In The L212 Ultrabass

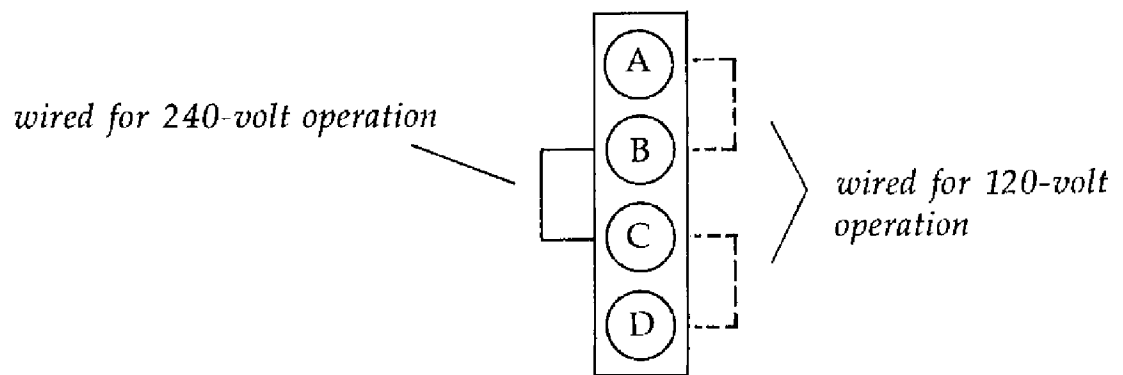

TB301 Terminal Strip

The Bass Energizer may be removed from the Ultrabass for service or shipment, as follows:

BASS ENERGIZER
REMOVAL

1. Remove the glass top, foam pad and grille. See the L212 Instruction Manual for complete details.
2. Be certain the main amplifier is switched off. Disconnect the Bass Energizer power cord from the AC outlet.
3. Place the enclosure upside down on a clean, padded surface. Disconnect the signal wires from the four terminals on the bottom of the unit.
4. Remove the six Phillips-head screws (two on the front and four on the bottom). Do not disturb any other screws or fasteners. Be sure to first uncoil the power cord from the retaining cleats to avoid interference when removing or replacing the mounting screws.
5. Gently lift the Bass Energizer from the enclosure approximately 3-4 inches (75-100 mm). Reach into the enclosure and disconnect the lead wires to the loudspeaker at the polarized connector, then continue removing the Bass Energizer.
6. Reverse this procedure for reinstallation. Note that the quick connector is polarized. Tighten all screws evenly, until snug. Do not overtighten.

The Bass Energizer is factory assembled for 120-volt, 50/60-Hz operation. It can be modified for 240-volt, 50/60-Hz operation, as follows:

240-VOLT OPERATION

1. Remove the Bass Energizer from the Ultrabass enclosure, as described.
2. Place the unit in front of you with the Power and Phase Reversal switches on the far edge of the chassis. Locate terminal TB301, which will be on the right.
3. Remove the jumper between terminals A and B and between C and D of TB301.
4. Solder a jumper (18-gauge bus wire) between terminals B and C.
5. Before reinstalling the Bass Energizer, be certain the unit meets other local requirements.
6. Replace the 2½-ampere, 3AG slow-blow fuse with a 1¼-ampere, 3AG slow-blow fuse, or equivalent.